



## SPRING INTO SAVINGS

### SAVE MONEY BY RESHARPENING YOUR DULL DRILLS

### Drill Resharpener Machines

For High Speed Steel, Cobalt and Carbide Straight Shank Drills

Using a patented design, with any standard precision ER collet for clamping and optimum drill alignment, these machines are simple to use with just three easy steps. Just set the drill in the collet, grind the taper relief angle and grind the web thinning angle to reduce the center point width - and DONE! Anyone can use these machines to resharpen dull drills **SAVING YOU MONEY!**

- Grind HSS, cobalt and carbide straight shank drills from 2-26 mm (*Carbide grinding wheel optional*)
- Reduce wear with double-bearing grinding unit
- Precision drill tightening fixture
- Adjustable 85° to 140° point angle



2-13 mm **1456.13**

Model DM-213  
Code 620001



12-26 mm **3334.65**

Model DM-1226  
Code 620002

	MODEL DM-213 Code 620001	MODEL DM-1226 Code 620002
DRILL DIAMETER	2 - 13 mm	12 - 26 mm
POINT ANGLE	85°-140°	
POWER SUPPLY	110V	
MOTOR	150 W	373 W
RPM	6000	4000
WEIGHT	10 kg	29 kg
DIMENSIONS   L X W X H	305 x 172 x 180 mm	470 x 260 x 235 mm
ER COLLETS INCLUDED	12 pcs. ER20 2.5 mm - 13 mm	15 pcs. ER40 12 mm - 26 mm
CBN DIAMOND WHEEL	1 pc. #200 (HSS drill)	1 pc. #150 (HSS drill)
HEXAGON WRENCH	4 mm and 5 mm	4 mm and 6 mm

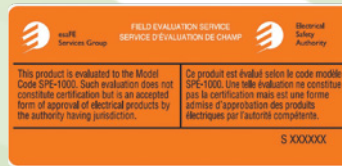

These products evaluated to the model code SPE-1000 by the Electrical Safety Authority

DETAILS AT KAR.CA: <https://kar.ca/catalogsearch/result/?q=620001+620002>

YOUR AUTHORIZED KAR DISTRIBUTOR:



**Toll Free Order Desk:**  
**1-800-263-1796**

**Web Site: [www.advancedtooling.com](http://www.advancedtooling.com)**  
**E-Mail: [atsinfo@advancedtooling.com](mailto:atsinfo@advancedtooling.com)**

## ADVANCED TOOLING SUPPLIES.

# SPRING INTO SAVINGS

SHAVIV Exclusively Available at **KAR** in Canada 

## HAND DEBURRING

### Extra Close Sets

Mango II Extra Close Bonus Packs

SHAVIV  
Leading Deburring Solutions



- For extra close applications
- Popular for deburring holes, slots and edges on most types of materials
- Includes 10 high speed steel blades and a Mango IIB or MangolIE handle
- Mango IIB and Mango IIE handles are designed for extra-close and heavy duty applications with a safety lock that prevents losing blades while working

Mango IIB Bonus Pack  
with 10 x B10 Blades  
Code 550992

17.26

Mango IIE Bonus Pack  
with 10 x E100 Blades  
Code 550993

21.53

### Blade Sets

Multi-Purpose | TiN Coated

SHAVIV  
Leading Deburring Solutions

Code 551001

35.17



Code 551000

42.56

SET B | Standard

5 pair of B blades: B10P (2), B11P (2), B12P (2), B20P (2), and B30P (2)

SET E | Heavy Duty

5 pair of E blades: E100P (2), E110P (2), E111P (2), E200P (2), E300P (2)

### CERAMIX Sets Heavy Duty Handles with Ceramic Blades

- Adjust cutting angle between blade and material for best results and prevent scratches
- Blade can be flipped for two types of jobs



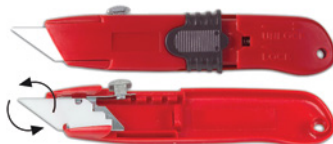

SHAVIV  
Leading Deburring Solutions

SET Q10  
Heavy Duty Handle  
with Ceramic Q10 Blade

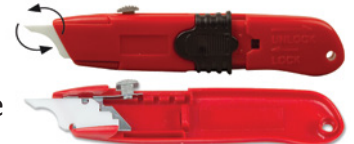

SET Q12  
Heavy Duty Handle with  
Curved Ceramic Q11 Blade



 Straight Edge  
 Flat Surface



Q10 Set  
with Q10 Blade  
Code 550722

30.26

 Straight Edge



Q12 Set  
with Q11 Blade  
Code 550726

30.26

### Individual Ceramic Blades

Side 1:  
Surface cleaner

Side 2:  
Cleans up to 0.236" (6mm) sheets  
Cleans up to 0.157" (4mm) sheets

Q10 Blade

Q10 Blade  
Code 550723

21.99

Side 1: Cleans curved edges  
and small ridges

Side 2:  
(same as Q10)

Q11 Curved Blade

Q11 Curved Blade  
Code 550728

21.99

EXCLUSIVELY AVAILABLE FROM **KAR** IN CANADA: <https://kar.ca/catalogsearch/result/index/?dir=asc&limit=45&order=relevance&q=SHAVIV>

### Mounted Points

General Purpose | W-Shape  
1/8", 1/4" & 3/8" Shanks



1/8" Shank  
Starting at...

1.51

1/4" Shank  
Starting at...

1.74

3/8" Shank  
Starting at...

5.70

ALL W-SHAPE  
MOUNTED POINTS  
ON SALE NOW

DETAILS AT KAR.CA: <https://kar.ca/abrasives-files-grinding/mounted-point/w-shape.html?limit=45>

# SAVINGS START NOW



## Cut Knurling Tools

For RAA Type Knurling



805.<sup>22</sup>/ea.

\*Knurling Holder and cutters sold separately

### Cut Knurls – Type AA and BR30°

- Knurls according to DIN403 for knurlings as DIN82
  - HRC 61±1 standard
  - High speed steel
  - Ground faces and central bore
  - Knurls sold individually
- 48.<sup>69</sup>/ea.

Pitch (mm)	Ø 21.5 BR30°	Ø 21.5 AA
		
	Code	Code
0.4	175434	175404
0.5	175435	175405
0.6	175436	175406
0.8	175438	175408
1.0	175440	175410
1.2	175442	175412
1.5	175445	175415
1.6	175446	175416
2.0	175450	175420

- Recommended for RAA type knurling (straight pattern - Type AA knurl)
- Pivoting head for knurl alignment
- Tool with reversible head able to fit on left hand or right hand lathes
- High speed steel TiN coated bushing
- Adjustment of tool clearance angle by threaded studs integrated in the shank

Model	Capacity (mm)	Knurl Size (mm)	Spare Bushing/Washer Code	Code
MFS14.53.16	Ø3÷50	14.5 x 3 x 5	175390	180184
MFS21.55.25	Ø4÷250	21.5 x 5 x 8	175490	180187

### Spare Bushing, Washer & Set Screw 3-piece Set for 21.5 cutter diameter



Code 175490

92.<sup>15</sup>

## CNC Spotting Drills

HSS-E Cobalt | Uncoated & RED-X Coated

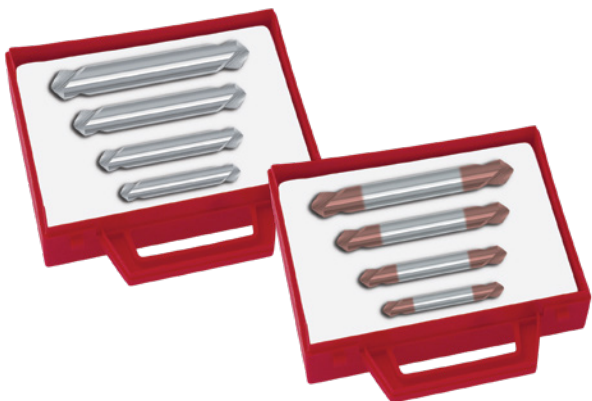

### 4-Piece Sets

(includes 1 of each individual size)

Uncoated  
Code 540090

RED-X Coated  
Code 540095

65.<sup>90</sup>

93.<sup>97</sup>

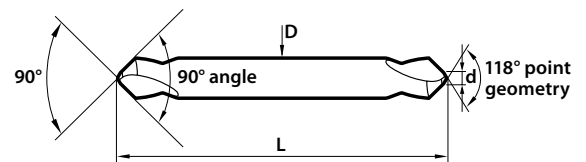

### Individual Spotting Drills

D (Inch)	d (Inch)	L (Inch)	90° Series 019 HSS-E COBALT		90° Series 0919 RED-X COATED	
			Code	Price	Code	Price
3/16	1/16	2	540091	10. <sup>64</sup>	540096	14. <sup>03</sup>
1/4	3/32	2	540092	11. <sup>30</sup>	540097	15. <sup>98</sup>
3/8	9/64	3	540093	17. <sup>68</sup>	540098	28. <sup>69</sup>
1/2	3/16	4	540094	27. <sup>37</sup>	540099	37. <sup>36</sup>

- 90° angle
- 118° point geometry for improved penetration rates while reinforcing the point
- Double ended for cost savings
- Available in 4-Piece sets or sold individually
- RED-X coating provides increased speeds and feeds and allows machining up to 55 HRC

<https://tinyurl.com/mr4dc5a2>

MORE SIZES & STYLES AT KAR

# SPRING INTO SAVINGS

## Combined Drills & Countersinks

High Speed Steel, TiN Coated & Cobalt | 60° Plain Type



60° HSS M2 (Series 115)



60° TiN Coated (Series 08115)



60° Cobalt (Series 1055)

Size	Body Diameter (Inch)	Point Diameter (Inch)	Point Length (Inch)	Overall Length (Inch)	(Series 115) HSS M2		(Series 08115) HSS M2 – TiN		(Series 1055) Cobalt M42	
					Code	Price	Code	Price	Code	Price
000	1/8	0.020	1/32	1-1/4	540599	8.88	-	-	-	-
00	1/8	0.025	1/32	1-1/4	540600	8.48	-	-	-	-
0	1/8	1/32	3/64	1-1/4	540610	7.74	-	-	-	-
1	1/8	3/64	1/16	1-1/4	540611	7.59	601000	14.96	540531	18.79
2	3/16	5/64	7/64	1-7/8	540612	7.95	601001	15.23	540532	19.36
3	1/4	7/64	9/64	2	540613	8.52	601002	21.29	540533	20.25
4	5/16	1/8	5/32	2-1/8	540614	9.73	601003	24.72	540534	21.39
5	7/16	3/16	1/4	2-3/4	540615	14.21	601004	30.58	540535	33.18
6	1/2	7/32	19/64	3	540616	18.30	601005	38.58	540536	49.43
7	5/8	1/4	5/16	3-1/4	540617	35.01	601006	59.73	540537	72.40
8	3/4	5/16	13/32	3-1/2	540618	56.87	601007	95.12	540538	112.60
9	7/8	11/32	7/16	3-5/8	540619	106.64	-	-	-	-
10	1	3/8	1/2	3-3/4	540598	117.53	-	-	-	-



### SAVE NOW

Featuring essentials for the Red Seal Machinist!

## Cast Aluminum Level

10 Inch | Magnetic Base



- ±0.006"/ft accuracy
- Shockproof horizontal and vertical vials
- Working temperature: 5°F-131°F
- Cast aluminum body
- Vials made in Israel – Lifetime warranty

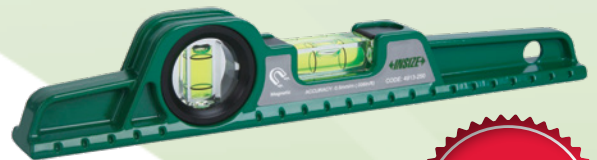

## Engineer's Black Book 3rd Edition

- Pocket size with 234 laminated, non-glare, tear and grease proof pages
- Non-slip rubberized cover
- Wired lay flat binding
- Self adhesive bookmark tabs



## Machinist's Measuring Set

Micrometer, Caliper & Steel Rule

- 0-1" micrometer with 0.0001" graduations
- 0-6" caliper with 0.001" graduations, 0-100 dial reading, shock proof
- 6" rule with 8ths, 16ths, 32nds and 64ths

Code 302255

49.98

**BLOWOUT PRICE**

**WHILE QUANTITIES LAST**



3  
PIECE  
SET

## Dial Indicators



- Meets ASME B89.1.10M-2001 standards
- Lug back
- Bezel locking clamp and limit pointers
- Contact point thread #4-48UNF
- Supplied in fitted storage case



### Precision Dial Indicator



Range: 0.05"  
Graduation: 0.0001"  
Code 282719

- Shock proof
- Jeweled bearing

**117.88**



### Large Face Dial Indicator



Range: 1.5"  
Graduation: 0.001"  
\*Code 282711

**83.80**

Range: 2"  
Graduation: 0.001"  
Code 282712

**94.66**

 [MORE DETAILS https://tinyurl.com/yckww6v5](https://tinyurl.com/yckww6v5)



## Electronic Radius Gage



Code 283213

**640.74**

- Measure radius of internal and external arcs
- External radius range: 0.2-35.83"/5-910mm
- Internal radius range: 0.3-35.83"/7-910mm
- Resolution: 0.00005"/0.005mm
- Accuracy: ±0.01R" (R is the radius to be measured)
- Buttons: on/off, hold, inch/mm, s (select jaws), zero
- Display may be rotated 320°
- Supplied with 5 separate jaws for multiple arc sizes
- Battery CR2032 | Auto power off
- Supplied in fitted storage case

 [MORE DETAILS](https://kar.ca/electronic-radius-gage-r5-700mm-0-2-27-5in.html)

<https://kar.ca/electronic-radius-gage-r5-700mm-0-2-27-5in.html>

## Magnifiers



### Three-Way Magnifier

2X Magnification, Lens Ø4.724"



4X Magnification  
Lens Ø1.102"

Code 816387

**29.09**

- Plastic lens
- Powered by 2 x AA batteries (included) or power adapter (110-240V, 50-60Hz)



### Magnifiers with Illumination

- Glass lens
- Powered by 3 x AAA batteries (included)

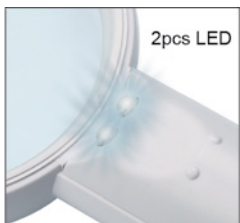

2pcs LED



2X Magnification  
Code 816388

**9.80**

4X Magnification  
Code 816389

**8.98**

## V-Blocks

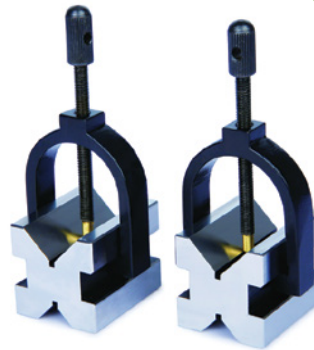

- Hold cylindrical work pieces for inspection and machining
- Hardened to HRC 60±2
- Parallelism of both v-grooves to top and bottom: 0.0002"
- Squareness of both v-grooves to front and back: 0.0002"
- Height difference of a matched pair: 0.0002"
- V-groove on top for large shafts
- V-groove on bottom for small shafts

1.97 (L) x 1.57 (W) x 1.57 (H)  
Shaft Range: Ø0.2"-1.18"

Code 889455

**227.65**

3.15 (L) x 2.48 (W) x 2.48 (H)  
Shaft Range: Ø0.28"-2.48"

Code 889456

**305.13**

3.94 (L) x 3.15 (W) x 3.15 (H)  
Shaft Range: Ø0.28"-3.15"

Code 889457

**442.08**

## Positioning Blocks



- Tapped holes provided for clamping operations
- Precision ground and hardened on all 6 sides
- Versatile for precision grinding layout work, etc.
- Squareness of all sides is within 0.0001"

1-2-3 Block Pair  
Tapped Hole: 3/8-16  
Code 440415

**24.09**

2-4-6 Block Pair  
Tapped Hole: 5/8-11  
Code 460170

**200.84**

# SPRING INTO SAVINGS

## Fixed Base Bench Vises

- Graded cast iron body
- Hardened and ground alloy steel jaws
- Perfectly aligned vise for smooth functioning

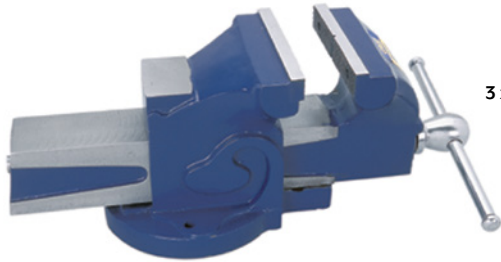

3 x 3-3/8 Inch Opening  
Code 416250

68.17

4 x 4 Inch Opening  
Code 416251

102.01

5 x 5 Inch Opening  
Code 416252

136.08

6 x 6 Inch Opening  
Code 416253

201.98

## Horizontal/Vertical Rotary Table

- Work table graduated 360° around circumference driven by a precision worm and gear providing a 90:1 reduction ratio
- One handle turn moves table through 4°
- Dial graduated in divisions of 1'
- Vernier scale allows readings down to 10 sec.
- Worm is hardened and precision ground to minimize wear of the worm gear
- Both the upper and lower surface of the rotary plates are precision ground
- Operation and service manual included

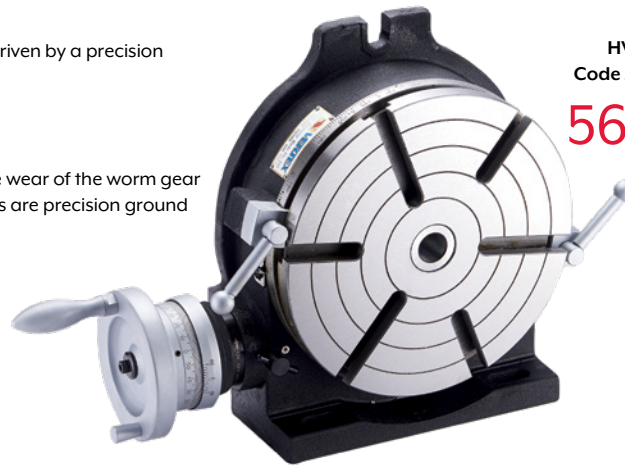

HV-6  
Code 277106

562.21

HV-8  
Code 277107

870.23

HV-10  
Code 277108

1081.45

HV-12  
Code 277109

1346.51

HV-16  
Code 277110

2542.59

### OPTIONAL ACCESSORIES:

Tail Stock, Dividing Plate Set, 3-Jaw Chuck

ALL DIMENSIONS AT KAR.CA [https://kar.ca/pdf/catalog\\_page/Kar\\_Catalog\\_Page\\_CAT17-pg420.pdf](https://kar.ca/pdf/catalog_page/Kar_Catalog_Page_CAT17-pg420.pdf)

## Power Table Feed

- Smooth running with high torque maximum of 650 in/lb
- New and stronger design assures long trouble-free life
- Electrical and mechanical parts are designed for easy maintenance

### Specifications:

Voltage: 110V, 50/60Hz  
Speed Range: 4-160 RPM  
Rapid Speed: 200 RPM  
Max. Torque: 650 lbs/in  
Dimensions:  
290 x 200 x 320mm  
Weight: 6.3kg



Code 302235

886.58

## Tray with #40 Inserts



Code 214200

113.69

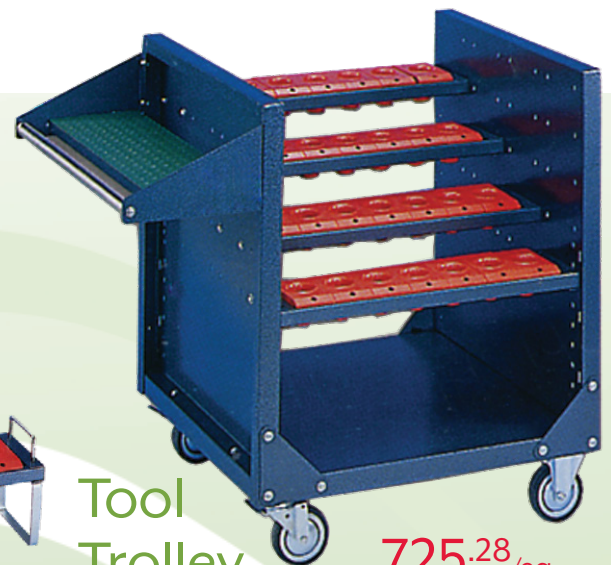

## Tool Trolley

725.28/ea.

With 28 pcs. #40 Inserts | Code 214140  
With 20 pcs. #50 Inserts | Code 214150

# SAVINGS START NOW

## Tool Holder Bushings

CNC Bushings | Black Oxide Finish | Types C, CV, B, DD, J & Z

- For use on all NC and CNC turning machines to adapt a wide variety of boring bars, drills, reamers and other round shank type tools
- Heat treated and precision ground



### Type C

- C bushings have long slots for clamping directly on the tool for positive alignment of the cutting edge of the tool

Type C  
Starting at...  
**43.91**



### Type DD

- DD bushings combine Type B split bushings and Type J with the set screw holes allowing this bushing to be used as either Type B or Type J
- Each bushing has a split, two or four holes and a flat

Type DD  
Starting at...  
**72.77**



### Type CV

- CV bushings have long slots for clamping directly on the tool for positive alignment of the cutting edge of the tool

Type CV  
Starting at...  
**49.78**



### Type J

- J bushings have a long solid body with two holes for clamping directly on the tool with set screws for positive alignment of the cutting edge of the tool

Type J  
Starting at...  
**49.78**



### Type B

- B bushings have splits and flats providing strong gripping of the tool shanks

Type B  
Starting at...  
**43.91**



### Type Z

- Z bushings have a long slot and two set screws in the bushing head
- Provides improved rigidity and reduced chatter

Type Z  
Starting at...  
**89.43**

MORE DETAILS AT KAR.CA: <https://kar.ca/catalogsearch/result/index/?cat=803&manufacturer=1750&q=Bushing>

## Shell Mill Adapters

CAT40

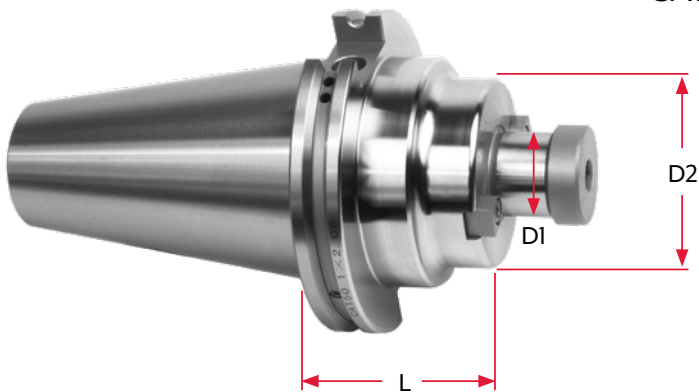

- Taper to pilot runout: <0.0002"
- Taper shank ground to AT3 accuracy or better
- H6 pilot tolerance
- AD+B coolant through spindle and flange
- Balanced by design
- Provided with a non-coolant arbor screw (coolant arbor screws sold separately)
- CAT40 draw bar threads: 5/8"-11
- CAT50 draw bar threads: 1"-8

D1 (Inch)	D2 (Inch)	L (Inch)	CAT40		
			Weight (lbs)	Code	Price
1/2	1.75	1.38	2.27	310989	79.99
		3.50	2.21	310990	79.99
3/4	1.75	4.00	3.80	310991	89.99
		2.06	3.10	310992	79.99
1	2.19	4.00	4.30	310993	89.99
		2.12	4.00	310994	79.99
1-1/4	2.75	4.00	5.00	310995	89.99
		2.41	5.01	310996	79.99
1-1/2	3.38	4.00	5.01	310997	89.99

# SPRING INTO SAVINGS

## Live Centers

High Speed Steel | Main Line Type N | Standard 60°



MAIN-LINE: Reliable top of the range live center for CNC and conventional lathes, and grinding machines

- Surface-hardened body
- Ground tapers conform to DIN228AT3
- Through-hardened spindle constructed from high-grade steel
- Spindle mounted by two needle bearings
- Thrust ball bearings to accommodate axial loads
- Over-pressure security through disc springs
- Reliable lip seal
- Continuous lubrication provided by a high quality grease



### BODY AND SPINDLE MODELS

ST | Standard for normal loads

SU | Super for heavy duty loads and low turning rates

ALL DIMENSIONS AT KAR.CA

<https://tinyurl.com/2d5hjphn>

MT1 STANDARD  
Code 100101

682.<sup>95</sup>

MT2 STANDARD  
Code 100102

590.<sup>20</sup>

MT2 SUPER  
Code 100112

678.<sup>74</sup>

MT3 SUPER  
Code 100113

758.<sup>84</sup>

MT4 STANDARD  
Code 100104

767.<sup>25</sup>

MT5 SUPER  
Code 100115

1416.<sup>51</sup>

MT6 STANDARD  
Code 100106

1682.<sup>11</sup>

## 3-Jaw Self-Centering Lathe Chucks



Universal | Plain Back Mounting | 2-Piece Hard Reversible Jaws

- Semi-steel body, medium duty
- 3 pinion design

Each chuck is provided with:

- 1 set of hard master jaws
- 1 set of hard top reversible jaws
- 1 chuck wrench
- 1 set of mounting bolts
- 2 hex keys
- Eye bolts with 10-32" chucks
- Adapters required for plain back mounting

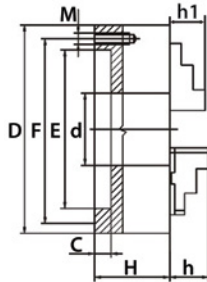

### PS Series - Plain Back Mounting Specifications

Chuck Diameter (Inch)	RPM Max	M Thread	Bolt Length (Inch)	No. of Bolts Required
5	3200	M8 x 1.25	0.98	3
6	3000	M10 x 1.5	0.98	6
8	2500	M10 x 1.5	0.98	6
10	2000	M12 x 1.75	1.18	6
12	1500	M16 x 2	1.18	6
16	1000	M16 x 2	1.57	6
20	700	M16 x 2	1.57	6
25	500	M16 x 2	1.97	6
32	300	1-8	5.96	6

D Chuck Diameter (Inch)	d Hole (Inch)	Maximum Hole Enlargements (Inch)	Model	C (Inch)	E (Inch)	F (Inch)	H (Inch)	h (Inch)	h1 (Inch)	Code	Price
5	1.26	1.35	PS3-5"A	0.16	3.74	4.25	2.20	1.57	0.79	356373	440. <sup>60</sup>
6	1.65	1.93	PS3-6"A	0.16	4.92	5.51	2.54	1.69	1.26	410009	548. <sup>77</sup>
8	2.17	2.82	PS3-8"A	0.16	6.30	6.93	2.95	1.77	1.14	410010	737. <sup>03</sup>
10	2.99	3.58	PS3-10"A	0.20	7.87	8.82	3.35	2.09	1.34	410003	985. <sup>35</sup>
12	4.06	4.33	PS3-12"A	0.20	10.24	11.26	3.70	2.24	1.69	410007	1462. <sup>03</sup>
16	5.35	5.75	PS3-16"A	0.20	12.99	14.25	4.13	2.69	2.16	410008	2195. <sup>02</sup>
20	7.48	8.35	PS3-20"A	0.24	16.54	18.03	4.53	3.50	2.20	356374	4750. <sup>55</sup>
25	9.92	12.05	PS3-25"A	0.28	21.46	23.07	5.16	3.46	2.76	356375	7930. <sup>93</sup>
32	12.60	-	PS3-32"A	0.79	17.72	14.50	6.26	3.46	2.76	356376	18088. <sup>10</sup>

KAR OFFERS THE GATOR CHUCK COMPLETE LINE! Ask your local Distributor for more details!



**KAR Industrial Inc.**  
[www.kar.ca](http://www.kar.ca)

Toronto.....1-800-387-3127  
Montréal.....1-800-363-7862  
Edmonton.....1-866-440-4326

Offer valid until June 30<sup>th</sup>, 2022

\*Products shown may not be exactly as illustrated Code 000317

FIND DISTRIBUTOR

MAKING IT EASY TO DO BUSINESS WITH SINCE 1954... CONTACT YOUR LOCAL KAR DISTRIBUTOR TODAY!